

# SERVICE BULLETIN

## PRIORITY 1 - SAFETY

**Service Bulletin No.** SB TMG 125-1021 P1, Initial Issue  
**Date:** September 21, 2016



**Subject:** Bushing Wastegate Lever

**Type affected:** TAE 125-02-99 and TAE 125-02-114

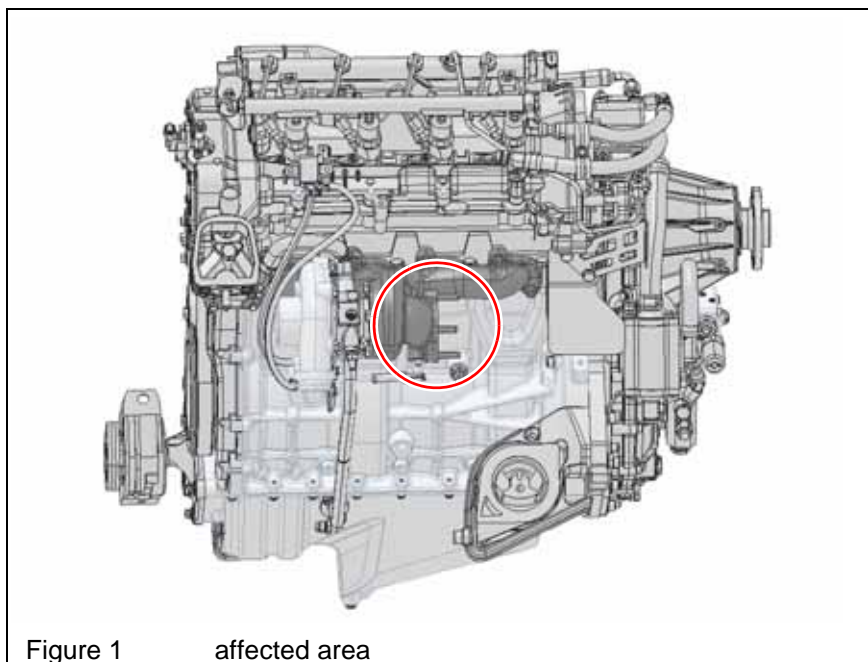
**Models affected:** TAE 125-02-99 up to Engine S/N 02-02-04170,  
except 02-02-04167 to 02-02-04169  
TAE 125-02-114 up to Engine S/N 02-02-10400,  
except 02-02-10199, 02-02-10201 and 02-02-10399



**Classification:** Category P1 – SAFETY

<b>Checked</b>  C. Rudolph, CVE	<b>Approved</b>  D. Hartung, Office of Airworthiness
--	--



Technify Motors GmbH  
Platanenstrasse 14  
09356 Sankt Egidien, Germany

Tel: +49 37204 696 0  
Fax: +49 37204 696 2912  
www.centurion-engines.com  
info@centurion-engines.com

SB TMG 125-1021 P1, Initial Issue

**Time of Compliance:** Engines up to 300 flight hours:  
Measures have to be accomplished with the 400 hours maintenance event.

Engines above 300 flight hours:  
Measures have to be accomplished within the next 100 flight hours or with the next maintenance action.

**Reason:** The bushing may move axially in the integral manifold. This can lead to an incorrect position of the wastegate flap and finally to a loss of power.

**Correction:** Fix the bushing in accordance with RM-02-02, Chapter 72-40.13, Issue 3, Revision 1 or later approved revisions.

**Remarks:** -

**Parts:**

Item	Part Number	Description	Quantity
Repair Set – Standard			
1	VR00624-00-00 01	repair set bush wastegate	1
1.1	VR00624-01-00 01	drilling fixture bush wastegate	1
1.1.1	VR00624-01-0103	angle drilling fixture	1
1.1.2	VR00624-01-0201	hexagon socket set screw	1
1.1.3	NM-0000-0076401	hexagon thin nut ISO 4035 - M6 - 04 - A2J	1
1.1.4	NM-0000-0004801	plain washer ISO 7092 - 8 - 200 HV - A2J	6
1.1.5	NM-0000-0129401	hexagon nut ISO 4032 - M8 - 8 - A2J	2
1.2	NM-0000-0243301	grooved pin ISO8740 - 2,5x120 - St	1
1.3	VW0639	twist drill HSSØ2,50	1
1.4	NM-0000-0003101	exhaust union nut M8-8-SW12-C2E	3
1.5	NM-0000-0141101	split pin ISO 1234-2x32-St-A2J	1
Repair Set – DA42			
1	VR00624-00-0101	repair set bush wastegate	1
1.1	VR00624-02-0001	drilling fixture bush wastegate	1
1.1.1	VR00624-02-0103	angle drilling fixture	1
1.1.2	VR00624-01-0201	hexagon socket set screw	1
1.1.3	NM-0000-0076401	hexagon thin nut ISO 4035 - M6 - 04 - A2J	1
1.1.4	NM-0000-0004801	plain washer ISO 7092 - 8 - 200 HV - A2J	6

**Replaces Service Bulletin No. / Date:**

-

Page 2 / 3



Technify Motors GmbH  
Platanenstrasse 14  
09356 Sankt Egidien, Germany

Tel: +49 37204 696 0  
Fax: +49 37204 696 2912  
www.centurion-engines.com  
info@centurion-engines.com

SB TMG 125-1021 P1, Initial Issue

Item	Part Number	Description	Quantity
1.1.5	NM-0000-0129401	hexagon nut ISO 4032 - M8 - 8 - A2J	2
1.2	NM-0000-0243301	grooved pin ISO8740 - 2,5x120 - St	1
1.3	VW0639	twist drill HSSØ2,50	1
1.4	NM-0000-0003101	exhaust union nut M8-8-SW12-C2E	3
1.5	NM-0000-0141101	split pin ISO 1234-2x32-St-A2J	1
Tools			
2		Pin Punch 150x2 (e.g. Rennsteig 450 002 150x2)	1
3		Pin Punch 150x4 (e.g. Rennsteig 450 004 150x4)	1

**Approval:**

The technical information contained in this document has been approved under the authority of EASA Design Organisation Approval No. EASA.21J.010.

**Replaces Service Bulletin No. / Date:**

-

Page 3 / 3